

0.2 mm Pitch, 0.9 mm Height FPC Connectors

FH43B Series

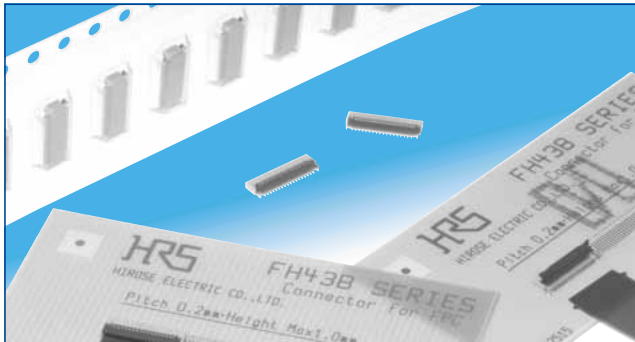

The staggered lead structure simplifies PCB mounting and provides a low profile height of 0.9 mm and a 2.77 mm mounting width depth.

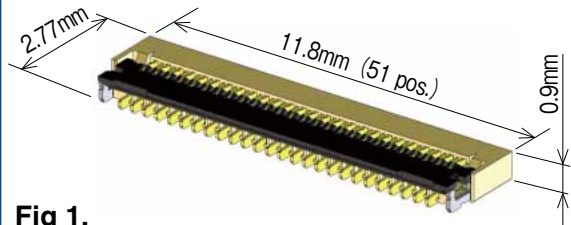

Fig 1.

■ Features

1. 0.2 mm pitch low profile bottom contact FPC connector

Maximizes space with contact pitch of 0.2 mm, a mated height of 0.9 mm, and mounted depth of 2.77 mm.

*45% reduction in occupied PCB area

*55% reduction in weight

(Compared to our 0.3 mm pitch FH26 Series 51 position connector)

2. Easy PCB mounting

The PCB leads use 0.4 mm pitch and are staggered which simplifies the PCB mounting process.

3. Supports high-speed transmissions

By utilizing differential pairs of identical contacts (even - even contact or odd - odd contacts) these connectors are able to provide superb transmission characteristics and supports eDP (ver. 1.3), MIPI (D-PHY), HDMI (ver 1.3), and USB (3.0) standards.

4. Molded structure aids PCB layout

The bottom of this connector is enclosed by a fully molded structure that protects the contacts and removes any restrictions from PCB patterning and layout design.

5. Rotating one-touch ZIF mechanism

The one-touch rotating ZIF mechanism is easier to operate and works with a light force, and a clear tactile click is delivered upon the successful completion of the mating process.

6. Easy FPC insertion

The FPC aligning mechanism holds onto the FPC prior to locking the actuator.

7. Insertion check window

There is a cutout on the actuator that allows you to visually inspect the FPC to make sure that it is locked into place, preventing incorrect insertion of the FPC.

8. Accepts standard 0.2 mm thick FPC

This connector accepts standard 0.2 mm thick FPC. (A stiffener with adequate strength will prevent FPC deformation and ease insertion and mating.)

9. Halogen-free available (FH43BW Series)

The connector does not use chlorine and bromine exceeding standard limits. (FH43BW Series)

*Defined in accordance with IEC61249-2-21

Br 900ppm or lower, Cl 900ppm or lower, Br + Cl 1,500ppm or lower

10. Available for 500 pieces packaging

Although the normal product is 5,000 pieces per reel, 500 winds per reel is also available.

(Emboss reel external diameter is ϕ 180mm.)

FH43B differential impedance

130ps rise time (20-80%)

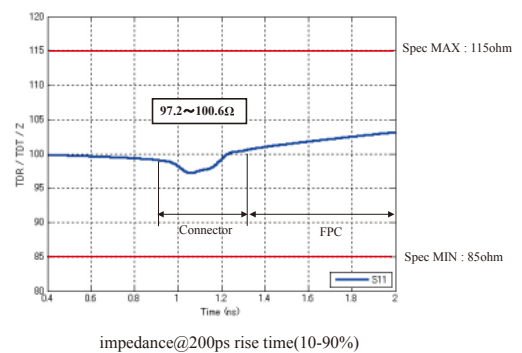

FPC insertion

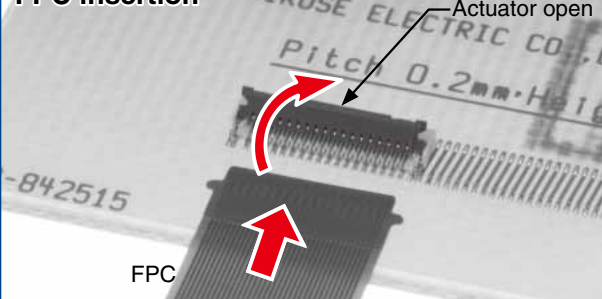

With actuator locked

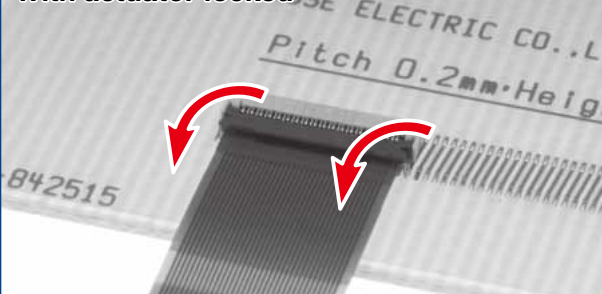

FPC temporary retention system

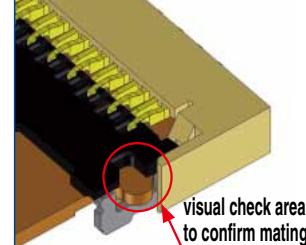
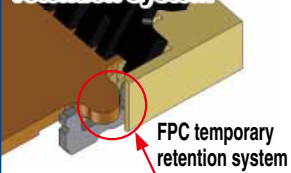

Product Specifications

Rating	Current Rating	DC 0.2 A (Note 1)	Operating Temperature Range	-55 to +85°C (Note 2)	Storage Temperature Range	-10 to +50°C (Note 3)
	Voltage Rating	AC 30 Vrms	Operating Humidity Range	Relative humidity 90% max (should be no condensation)	Storing Humidity Range	Relative humidity 90% max (should be no condensation)

Recommended FPC spec	t = 0.2 ±0.02 Gold plating
----------------------	----------------------------

Items	Specifications	Conditions
1. Insulation Resistance	50 MΩ Min	100 V DC
2. Withstanding Voltage	No flashover or breakdown	90 V AC for 1 Min
3. Contact Resistance	100 mΩ Max. *Excluding FPC conductor resistance	1 mA
4. Durability	Contact Resistance: 100 mΩ Max No damage, cracks and looseness of parts	10 cycles
5. Vibration	No electrical discontinuity of 1μ or longer Contact Resistance: 100 mΩ Max No damage, cracks and looseness of parts	Frequency 10 to 55Hz, Half amplitude 0.75 mm for 10 cycles in 3 axial directions
6. Shock	No electric discontinuity of 1μ or longer Contact Resistance: 100 mΩ Max No damage, cracks and looseness of parts	Acceleration: 981 m/s ² , Retention time: 6 ms, Semi-sinusoidal 3 times in 3 both axial directions
7. Humidity (Steady State)	Contact Resistance: 100 mΩ Max Insulation Resistance: 50 MΩ Min No damage, cracks and looseness of parts	96 hours at 40°C and humidity of 90 to 95%
8. Temperature Cycle	Contact Resistance: 100 mΩ Max Insulation Resistance: 50 MΩ Min No damage, cracks and looseness of parts	Temperature: -55 → +15 to +35 → +85 → +15 to +35°C Time: 30 → 2 to 3 → 30 → 2 to 3 minutes 5 cycles
9. Resistance to soldering heat	No deformation of case of excessive looseness of the terminal	1) Reflow: Peak TMP 250°C MAX, reflow TMP over 230°C within 60 seconds 2) Manual soldering: 350 ±10°C for 5 seconds

(Note 1) When electrifying rated current to all contacts, use 70% of rated current.

(Note 2) Includes temperature rise caused by current flow.

(Note 3) The term "storage" refers to the long-term storage condition of unused products before PCB mounting.

For no-electrification state after PCB mounting, the operating temperature and humidity are applied.

Materials

Product	Materials	Color/Finish	Remarks
Insulator	LCP	Beige	UL94V-0
	PA	FH43B Series: Deep brown FH43BW Series: Black	
Contacts	Phosphor bronze	Gold plating	—
Metal fittings		Pure tin reflow plating	—

Product Number Structure

Refer to this page when determining product specifications by model types. Please place orders with part numbers listed in this catalog. The characteristics and specifications of the product described in this catalog are reference values. Please make sure to check the latest delivery specifications at the time of product use.

FH 43B W - 51S - 0.2 SHW (10)

① ② ③ ④ ⑤ ⑥ ⑦

① Series Name: FH	⑥ Terminal Type SHW ... SMT horizontal staggered row mounting type
② Series No.: 43B	⑦ Specifications (10):Nickel barrier gold plating, 5,000 pieces per reel (99):Nickel barrier gold plating 500 pieces per reel
③ Blank: Standard W: Halogen-free product	
④ No. of Contacts: 21~71	
⑤ Contact Pitch: 0.2 mm	

Connector Dimensions

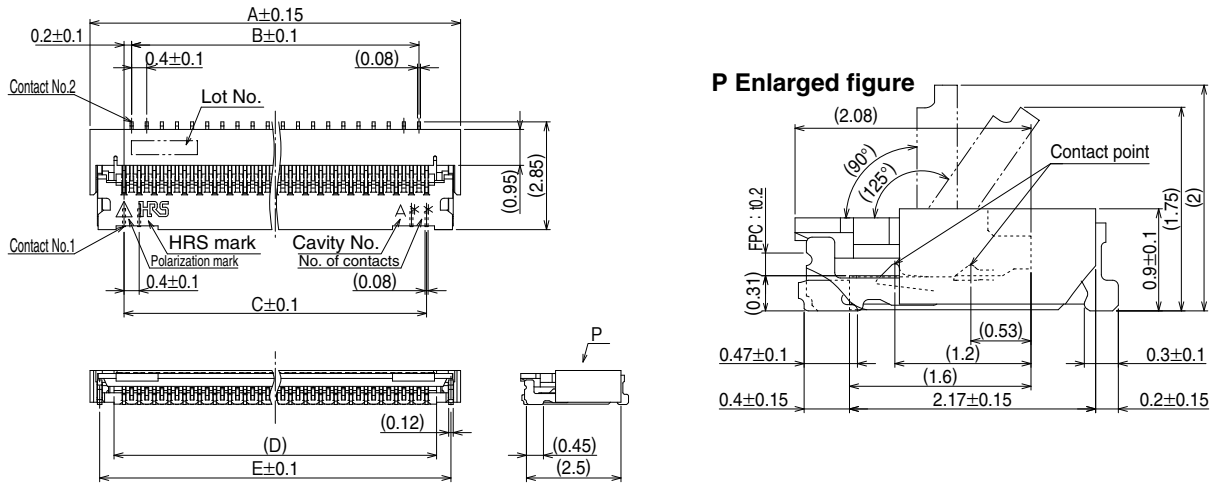

Note 1: The dimensions in parentheses are for reference.

2: Lead coplanarity including reinforced metal fittings shall be 0.1 mm MAX.

3: To be delivered with tape and reel packages. See attached packaging specifications for details.

4: Note that preventive hole for sink mark or slit could be added for improvement.

5: The quality remains good, even with the dark spots, which could occasionally occur on molded plastic.

6: The color of the plating may change after the reflow process, but it will not negatively affect the performance of these connectors.

Unit: mm

Product No.	HRS No.	No. of Contacts	A	B	C	D	E
FH43B-21S-0.2SHW(**)	CL580-2810-0-**-	21	5.8	3.6	4	4.53	5.29
FH43B-25S-0.2SHW(**)	CL580-2804-8-**-	25	6.6	4.4	4.8	5.33	6.09
FH43B-29S-0.2SHW(**)	CL580-2811-3-**-	29	7.4	5.2	5.6	6.13	6.89
FH43B-31S-0.2SHW(**)	CL580-2808-9-**-	31	7.8	5.6	6	6.53	7.29
FH43B-35S-0.2SHW(**)	CL580-2803-5-**-	35	8.6	6.4	6.8	7.33	8.09
FH43B-41S-0.2SHW(**)	CL580-2809-1-**-	41	9.8	7.6	8	8.53	9.29
FH43B-45S-0.2SHW(**)	CL580-2812-6-**-	45	10.6	8.4	8.8	9.33	10.09
FH43B-51S-0.2SHW(**)	CL580-2806-3-**-	51	11.8	9.6	10	10.53	11.29
FH43B-61S-0.2SHW(**)	CL580-2805-0-**-	61	13.8	11.6	12	12.53	13.29
FH43B-71S-0.2SHW(**)	CL580-2807-6-**-	71	15.8	13.6	14	14.53	15.29

Product No.	HRS No.	No. of Contacts	A	B	C	D	E
FH43BW-21S-0.2SHW(**)	CL580-2822-0-**-	21	5.8	3.6	4	4.53	5.29
FH43BW-25S-0.2SHW(**)	-	25	6.6	4.4	4.8	5.33	6.09
FH43BW-29S-0.2SHW(**)	-	29	7.4	5.2	5.6	6.13	6.89
FH43BW-31S-0.2SHW(**)	CL580-2820-4-**-	31	7.8	5.6	6	6.53	7.29
FH43BW-35S-0.2SHW(**)	CL580-2821-7-**-	35	8.6	6.4	6.8	7.33	8.09
FH43BW-41S-0.2SHW(**)	CL580-2813-9-**-	41	9.8	7.6	8	8.53	9.29
FH43BW-45S-0.2SHW(**)	CL580-2815-4-**-	45	10.6	8.4	8.8	9.33	10.09
FH43BW-51S-0.2SHW(**)	CL580-2814-1-**-	51	11.8	9.6	10	10.53	11.29
FH43BW-61S-0.2SHW(**)	CL580-2816-7-**-	61	13.8	11.6	12	12.53	13.29
FH43BW-71S-0.2SHW(**)	CL580-2819-5-**-	71	15.8	13.6	14	14.53	15.29

(Note 1) This product is packaged on tape and reel and is only sold in full reel quantities of either 5,000 or 500 piece reels. Please place orders by full reel quantities.

Recommended PCB Mounting Pattern

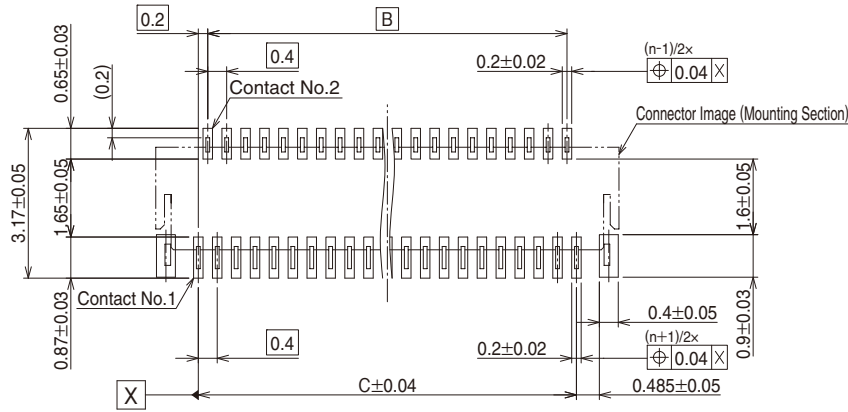

Recommended Stencil Pattern

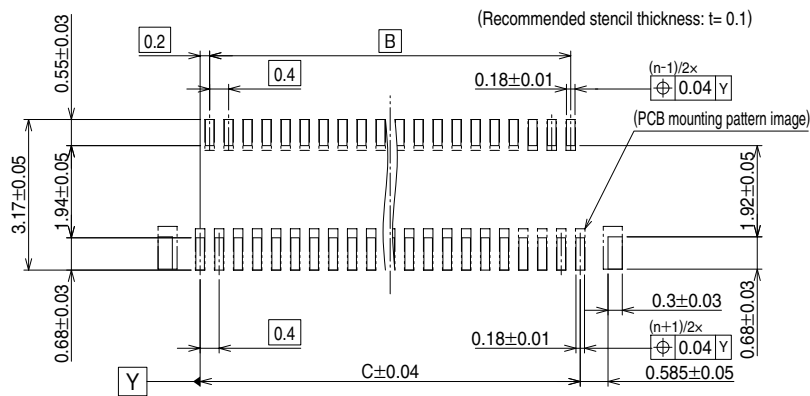

Note 7: 'n' is the number of contacts.

Unit: mm

Product No.	HRS No.	No. of Contacts	B	C
FH43B-21S-0.2SHW(**)	CL580-2810-0-**-	21	3.6	4
FH43B-25S-0.2SHW(**)	CL580-2804-8-**-	25	4.4	4.8
FH43B-29S-0.2SHW(**)	CL580-2811-3-**-	29	5.2	5.6
FH43B-31S-0.2SHW(**)	CL580-2808-9-**-	31	5.6	6
FH43B-35S-0.2SHW(**)	CL580-2803-5-**-	35	6.4	6.8
FH43B-41S-0.2SHW(**)	CL580-2809-1-**-	41	7.6	8
FH43B-45S-0.2SHW(**)	CL580-2812-6-**-	45	8.4	8.8
FH43B-51S-0.2SHW(**)	CL580-2806-3-**-	51	9.6	10
FH43B-61S-0.2SHW(**)	CL580-2805-0-**-	61	11.6	12
FH43B-71S-0.2SHW(**)	CL580-2807-6-**-	71	13.6	14

Product No.	HRS No.	No. of Contacts	B	C
FH43BW-21S-0.2SHW(**)	CL580-2822-0-**-	21	3.6	4
FH43BW-25S-0.2SHW(**)	-	25	4.4	4.8
FH43BW-29S-0.2SHW(**)	-	29	5.2	5.6
FH43BW-31S-0.2SHW(**)	CL580-2820-4-**-	31	5.6	6
FH43BW-35S-0.2SHW(**)	CL580-2821-7-**-	35	6.4	6.8
FH43BW-41S-0.2SHW(**)	CL580-2813-9-**-	41	7.6	8
FH43BW-45S-0.2SHW(**)	CL580-2815-4-**-	45	8.4	8.8
FH43BW-51S-0.2SHW(**)	CL580-2814-1-**-	51	9.6	10
FH43BW-61S-0.2SHW(**)	CL580-2816-7-**-	61	11.6	12
FH43BW-71S-0.2SHW(**)	CL580-2819-5-**-	71	13.6	14

Recommended FPC Pattern

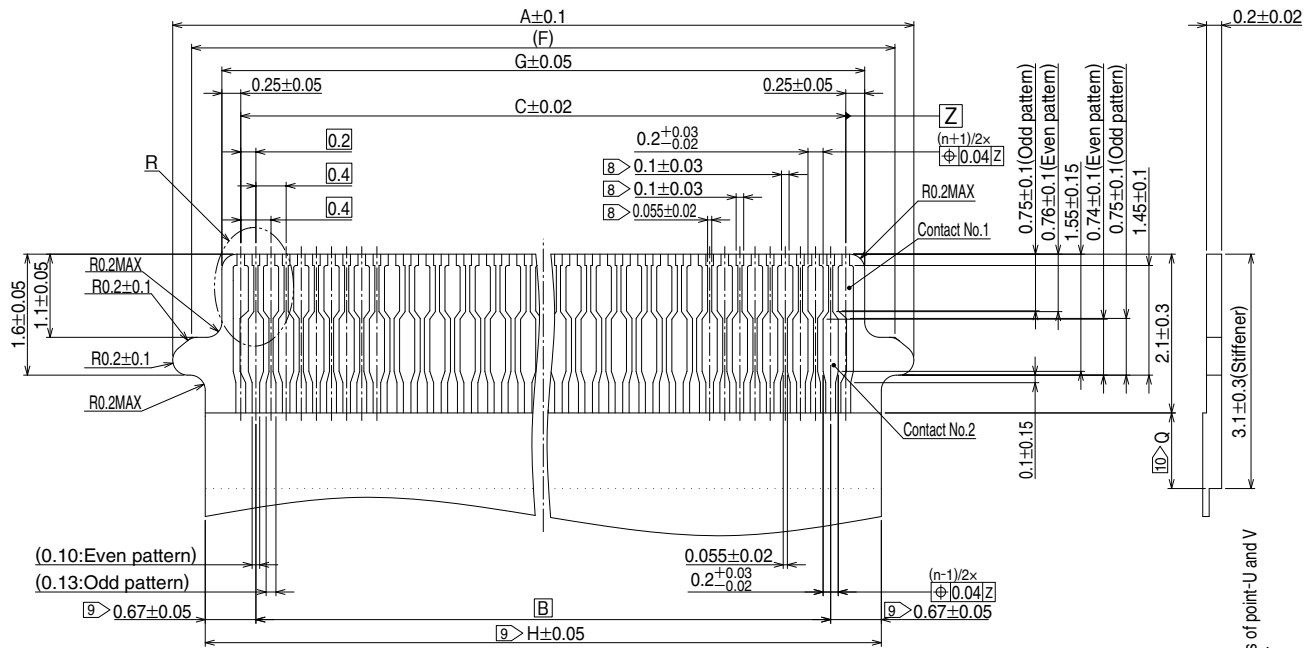

R Enlarged figure

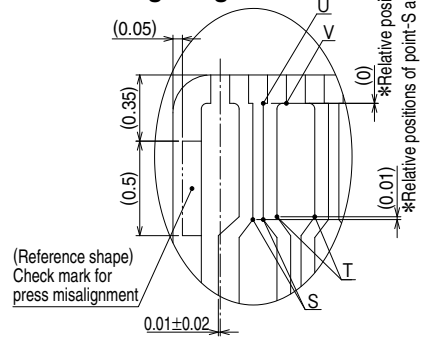

- Note
- ⑧ : Shows recommended demension when lead for plating is required.
 - ⑨ : Indicated tolerance is applicable to the exposed conductor.
 - ⑩ : Dimension Q must be 0.5 mm minimum.

Unit: mm

Product No.	HRS No.	No. of Contacts	A	B	C	F	G	H
FH43B-21S-0.2SHW(**)	CL580-2810-0-**-	21	5.8	3.6	4	5.3	4.5	4.94
FH43B-25S-0.2SHW(**)	CL580-2804-8-**-	25	6.6	4.4	4.8	6.1	5.3	5.74
FH43B-29S-0.2SHW(**)	CL580-2811-3-**-	29	7.4	5.2	5.6	6.9	6.1	6.54
FH43B-31S-0.2SHW(**)	CL580-2808-9-**-	31	7.8	5.6	6	7.3	6.5	6.94
FH43B-35S-0.2SHW(**)	CL580-2803-5-**-	35	8.6	6.4	6.8	8.1	7.3	7.74
FH43B-41S-0.2SHW(**)	CL580-2809-1-**-	41	9.8	7.6	8	9.3	8.5	8.94
FH43B-45S-0.2SHW(**)	CL580-2812-6-**-	45	10.6	8.4	8.8	10.1	9.3	9.74
FH43B-51S-0.2SHW(**)	CL580-2806-3-**-	51	11.8	9.6	10	11.3	10.5	10.94
FH43B-61S-0.2SHW(**)	CL580-2805-0-**-	61	13.8	11.6	12	13.3	12.5	12.94
FH43B-71S-0.2SHW(**)	CL580-2807-6-**-	71	15.8	13.6	14	15.3	14.5	14.94

Product No.	HRS No.	No. of Contacts	A	B	C	F	G	H
FH43BW-21S-0.2SHW(**)	CL580-2822-0-**-	21	5.8	3.6	4	5.3	4.5	4.94
FH43BW-25S-0.2SHW(**)	-	25	6.6	4.4	4.8	6.1	5.3	5.74
FH43BW-29S-0.2SHW(**)	-	29	7.4	5.2	5.6	6.9	6.1	6.54
FH43BW-31S-0.2SHW(**)	CL580-2820-4-**-	31	7.8	5.6	6	7.3	6.5	6.94
FH43BW-35S-0.2SHW(**)	CL580-2821-7-**-	35	8.6	6.4	6.8	8.1	7.3	7.74
FH43BW-41S-0.2SHW(**)	CL580-2813-9-**-	41	9.8	7.6	8	9.3	8.5	8.94
FH43BW-45S-0.2SHW(**)	CL580-2815-4-**-	45	10.6	8.4	8.8	10.1	9.3	9.74
FH43BW-51S-0.2SHW(**)	CL580-2814-1-**-	51	11.8	9.6	10	11.3	10.5	10.94
FH43BW-61S-0.2SHW(**)	CL580-2816-7-**-	61	13.8	11.6	12	13.3	12.5	12.94
FH43BW-71S-0.2SHW(**)	CL580-2819-5-**-	71	15.8	13.6	14	15.3	14.5	14.94

◆FPC Material Configuration (Reference Example)

Single-Sided FPC

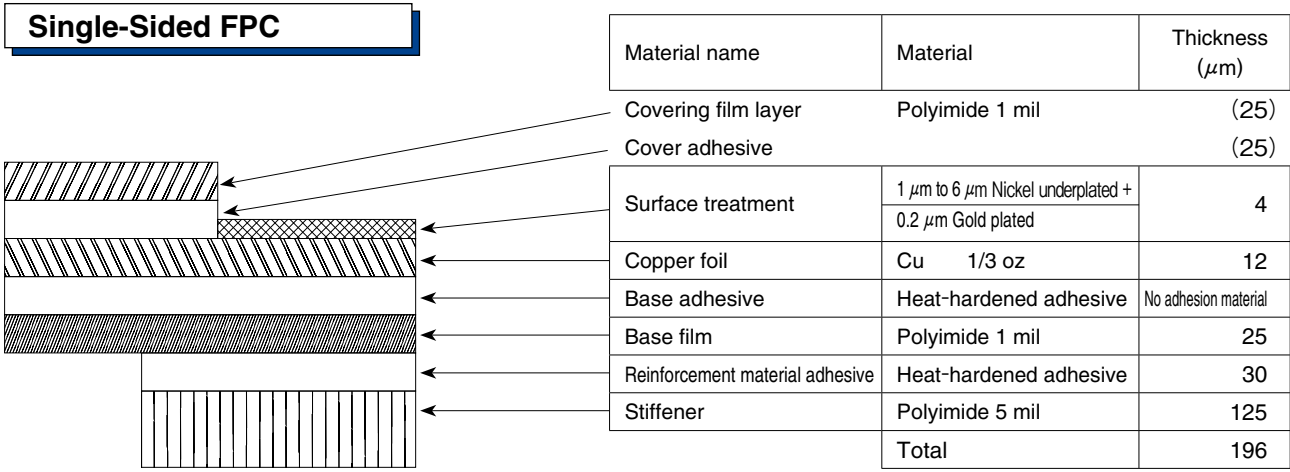

Precautions

1. This specification is a recommendation for the construction of the FH43B Series FPC (t=0.2±0.02).
2. For details about the construction, please contact the FPC manufacturers.

◆ Packaging Specifications

● Embossed Carrier Tape Dimension (Tape width: 24 mm MAX)

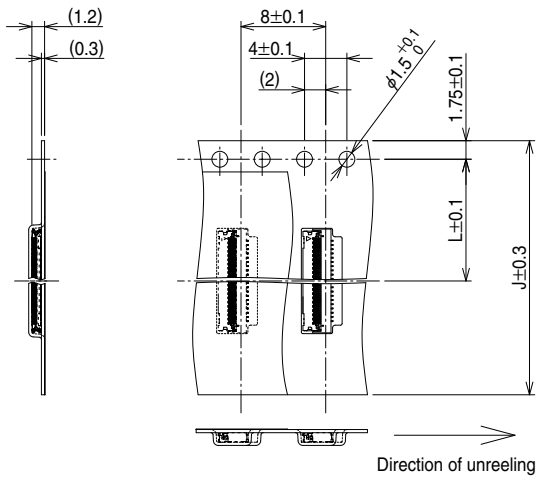

● Embossed Carrier Tape Dimension (Tape width: 32 mm MIN)

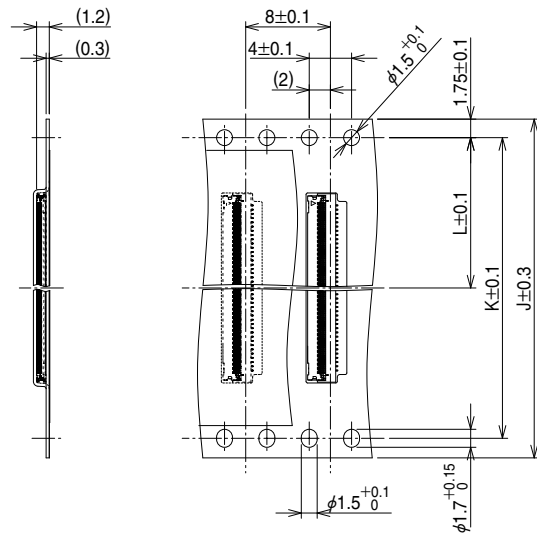

● Reel Condition Dimensions

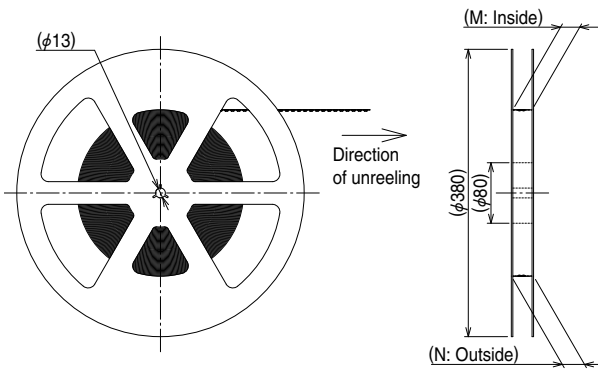

● Leader, Trailer Dimensions

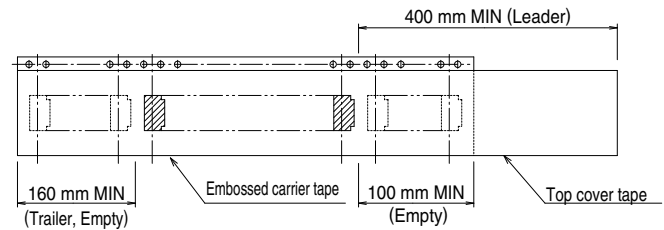

Unit: mm

Product No.	HRS No.	No. of Contacts	J	K	L	M	N
FH43B-21S-0.2SHW(**)	CL580-2810-0-**-	21	16	-	7.5	17.4	21.4
FH43B-25S-0.2SHW(**)	CL580-2804-8-**-	25	16	-	7.5	17.4	21.4
FH43B-29S-0.2SHW(**)	CL580-2811-3-**-	29	16	-	7.5	17.4	21.4
FH43B-31S-0.2SHW(**)	CL580-2808-9-**-	31	24	-	11.5	25.4	29.4
FH43B-35S-0.2SHW(**)	CL580-2803-5-**-	35	24	-	11.5	25.4	29.4
FH43B-41S-0.2SHW(**)	CL580-2809-1-**-	41	24	-	11.5	25.4	29.4
FH43B-45S-0.2SHW(**)	CL580-2812-6-**-	45	24	-	11.5	25.4	29.4
FH43B-51S-0.2SHW(**)	CL580-2806-3-**-	51	24	-	11.5	25.4	29.4
FH43B-61S-0.2SHW(**)	CL580-2805-0-**-	61	24	-	11.5	25.4	29.4
FH43B-71S-0.2SHW(**)	CL580-2807-6-**-	71	32	28.4	14.2	33.4	37.4

Product No.	HRS No.	No. of Contacts	J	K	L	M	N
FH43BW-21S-0.2SHW(**)	CL580-2822-0-**-	21	16	-	7.5	17.4	21.4
FH43BW-25S-0.2SHW(**)	-	25	16	-	7.5	17.4	21.4
FH43BW-29S-0.2SHW(**)	-	29	16	-	7.5	17.4	21.4
FH43BW-31S-0.2SHW(**)	CL580-2820-4-**-	31	24	-	11.5	25.4	29.4
FH43BW-35S-0.2SHW(**)	CL580-2821-7-**-	35	24	-	11.5	25.4	29.4
FH43BW-41S-0.2SHW(**)	CL580-2813-9-**-	41	24	-	11.5	25.4	29.4
FH43BW-45S-0.2SHW(**)	CL580-2815-4-**-	45	24	-	11.5	25.4	29.4
FH43BW-51S-0.2SHW(**)	CL580-2814-1-**-	51	24	-	11.5	25.4	29.4
FH43BW-61S-0.2SHW(**)	CL580-2816-7-**-	61	24	-	11.5	25.4	29.4
FH43BW-71S-0.2SHW(**)	CL580-2819-5-**-	71	32	28.4	14.2	33.4	37.4

◆ Temperature Profile

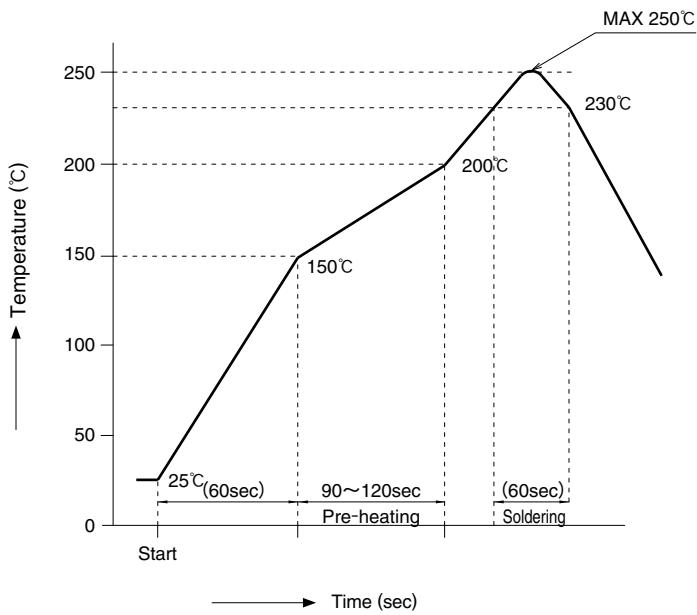

Applicable Conditions

Reflow method : IR/Hot air

Reflow environment : Room air

Solder : Paste type Sn/3.0Ag/0.5Cu
(M705-GRN360-K2-V made by Senju Metal Industry Co.)

Test PCB : PCB material and size
Glass epoxy 100×72.5×0.8mm
Land pattern 0.2×0.65, 0.2×0.87mm

Stencil : Thickness 0.1mm
Opening size 0.18×0.55, 0.18×0.68mm

The temperature profiles are based on the above conditions.

In individual applications the actual temperature may vary, depending on solder paste type, volume/thickness and board size/thickness.

Consult your solder paste and equipment manufacturer for specific recommendations.

◆ Operation and Precautions

Operation Methods

This connector needs to be handled with care due to its thin design and miniature stature. Please refer to the following descriptions for handling precautions.

1. Initial Delivery Condition

- ① The connector is delivered with the actuator closed.

[Caution]

- Do not insert FPC or operate actuator before mounting.

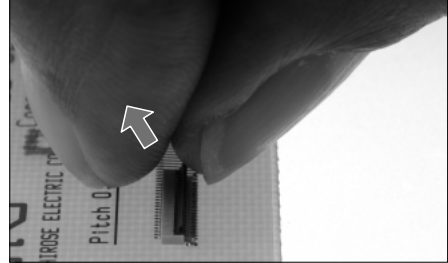

2. How to unlock

- ① Rotate slowly flip up the actuator to release the lock.

[Caution]

- When operating the actuator do not apply any force in the direction of the connector.
 - The actuator rotates 125 degrees max.
- Do not attempt to force the actuator to backside further.

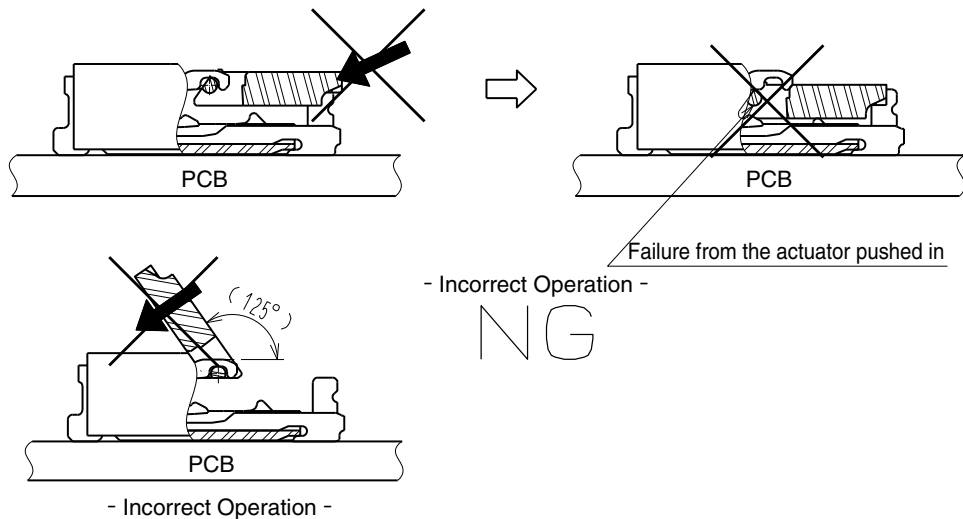

3. How to insert FPC

- ① This connector has contacts on the bottom. Insert the FPC with the exposed conductors face down.

[Caution]

- Insert the FPC with the actuator opened.
- This connector utilizes metal fittings designed to align the FPC.
- Do not twist the FPC to up and down, right and left or an angle.

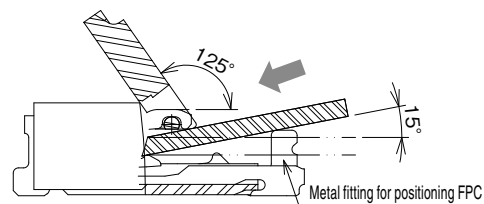
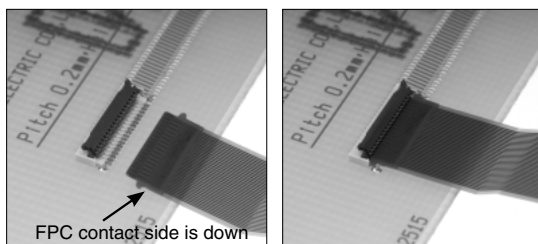

Operation Methods

4. FPC insertion check

① Metal fittings guide the FPC tabs to the correct position.

Make sure that the FPC tabs are located in correct position as shown in the figure below after FPC insertion.

[Caution]

- Do not insert the FPC at an angle and/or stop it before insertion is completed.

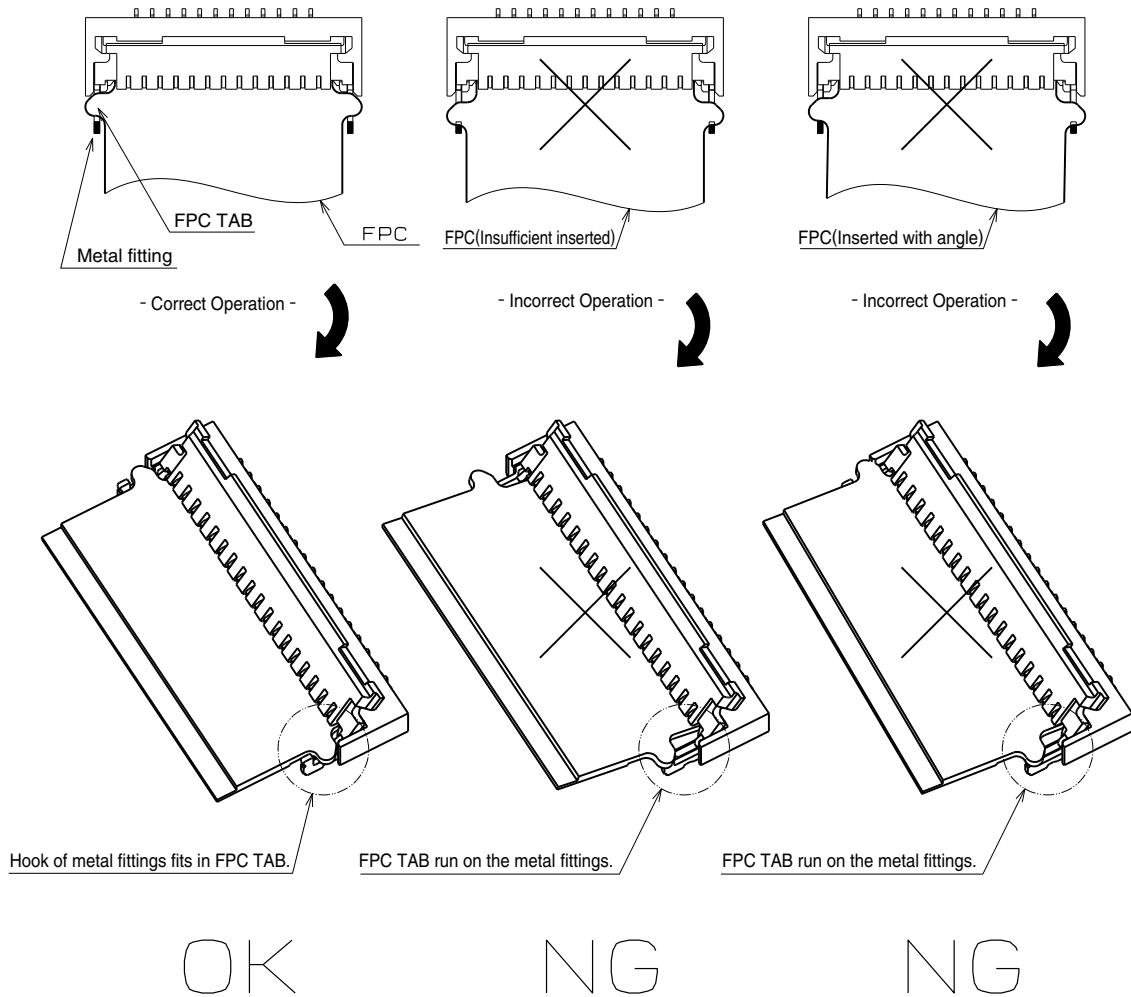

5. How to lock

① Apply load to rotate the actuator after inserting the FPC.

[Caution]

- The actuator rotates on its axis. Make sure to operate the actuator with a rotating motion.
- In order to lock the actuator, apply force to the center of the actuator.
- Do not operate the actuator at one end only.
- Do not apply excessive force during this operation, the lock.

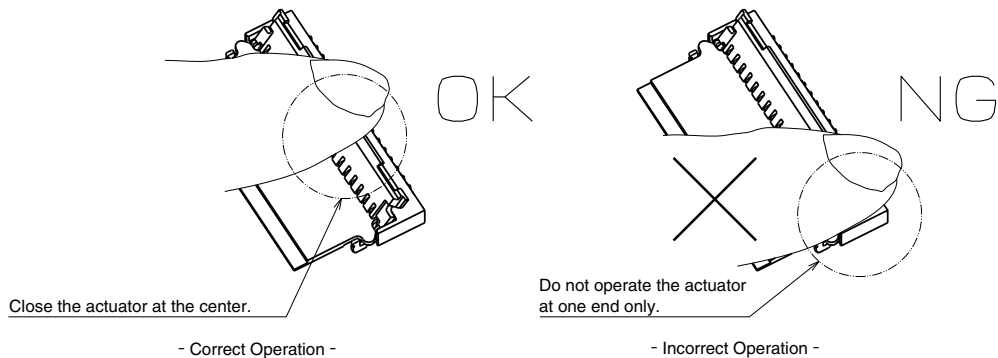

Operation Methods

6. Mating confirmation of the FPC

- This connector uses reinforced metal fittings to align the FPC. Visually confirm the FPC positioning after closing the actuator.

[Caution]

- Do not insert the FPC at an angle and/or stop it before insertion is completed.

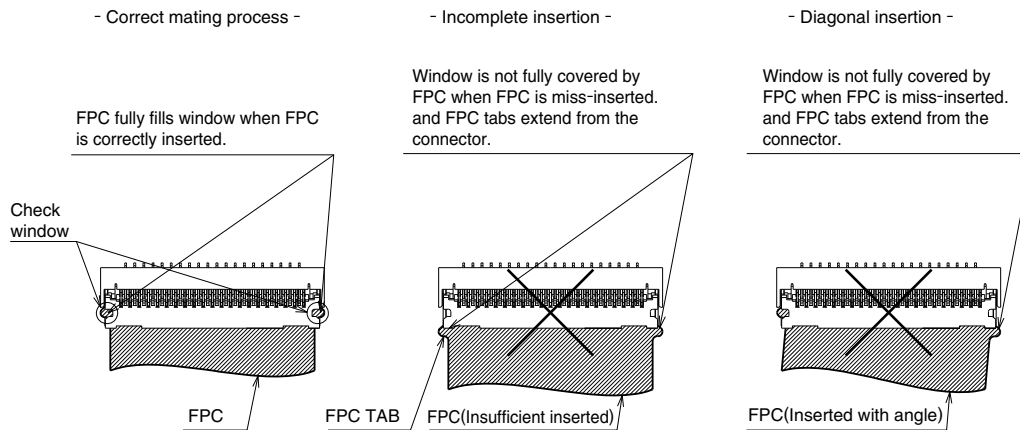

7. FPC Withdrawal (Unlock)

- Rotate slowly flipup the actuator to release the lock.
- After rotating the actuator to the fully opened position carefully withdraw the FPC pulling out at about 15 degree angle to the PCB mounting surface.

[Caution]

- Open the actuator by carefully lifting it at the center.
- Do not operate the actuator at one end only.

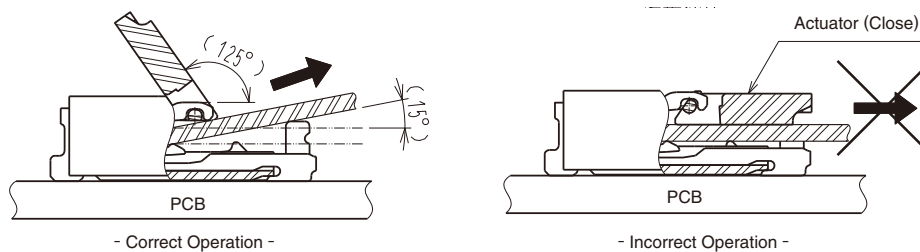

8. FPC routing after connecting

- Depending on a FPC rounding, a load is applied to the connector, and a contact failure may occur. To prevent a failure, take the following notes into a consideration during mechanism design.

[Caution]

- Make sure that the FPC and its stiffener do not contact chassis.
- Avoid applying forces to FPC in vertical or horizontal directions. In addition, avoid pulling up and down on the FPC.
- When fixing FPC after FPC cabling, avoid pulling FPC, and route the wire FPC with slack. In this regard, the stiffener is parallel to the PCB.
- Do not mount other components touching to the FPC underneath the FPC stiffener.

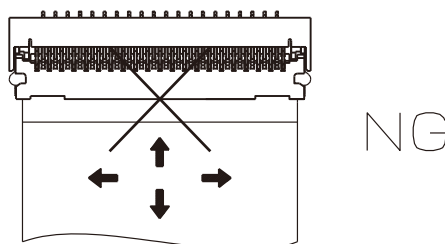

Cautions when Mounting PCB

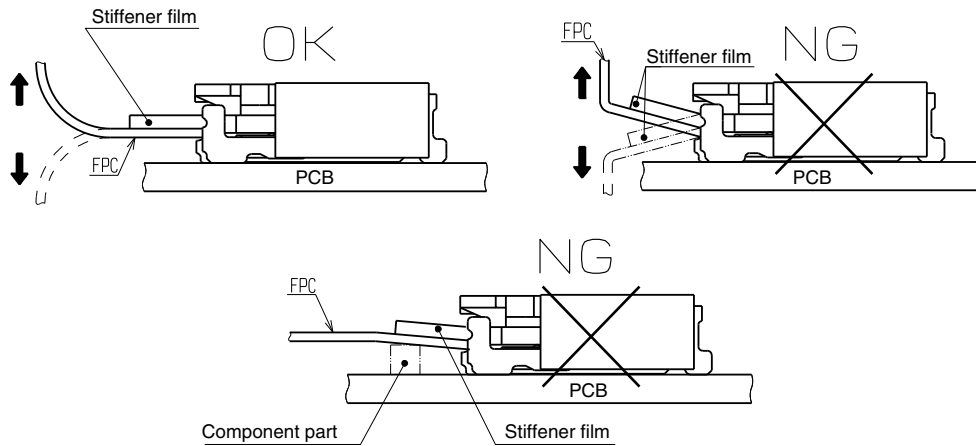

◆ Warp of PCB

Minimize warp of the PCB as much as possible. Lead co-planarity including reinforced metal fittings is 0.1 mm or less. Too much warp of the PCB may result in a soldering failure.

◆ Flexible board design

Please make sure to put a stiffener on the backside of the flexible board. We recommend a glass epoxy material with the thickness of 0.3 mm MIN.

◆ Load to Connector

Do not add 0.5N or greater external force when unreel or pick and place the connector etc, or it may get broken. In addition, do not insert the FPC or operate the connector before mounting.

◆ Load to PCB

- Splitting a large PCB into several pieces
- Screwing the PCB

Avoid the handling described above so that no force is exerted on the PCB during the assembly process. Otherwise, the connector may become defective.

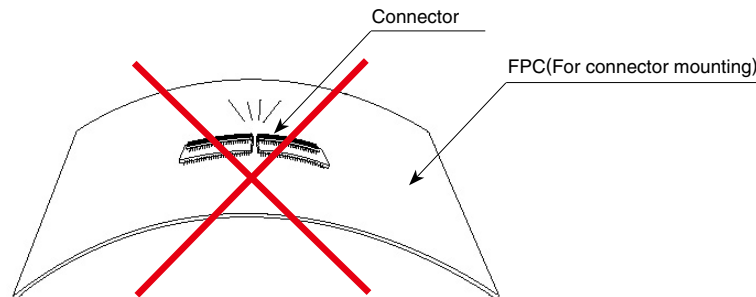

◆ Instructions on manual soldering

Follow the instructions shown below when soldering the connector manually during repair work, etc.

- ① Do not perform manual soldering with the FPC inserted into the connector.
- ② Do not heat the connector excessively. Be very careful not to let the soldering iron contact any parts other than connector leads. Otherwise, the connector may be deformed or melt.
- ③ Do not supply excessive solder (or flux).

If excessive solder (or flux) is supplied on the terminals, solder or flux may adhere to the contacts or rotating parts of the actuator, resulting in poor contact or a rotation failure of the actuator.

Supplying excessive solder to the metal fittings may hinder actuator rotation, resulting in breakage of the connector.



HIROSE ELECTRIC CO.,LTD.

6-3,Nakagawa Chuoh-2-Chome,Tsuzuki-Ku,Yokohama-Shi 224-8540,JAPAN

TEL: +81-45-620-3526 Fax: +81-45-591-3726

<http://www.hirose.com>

<http://www.hirose-connectors.com>